

TCAD Unlimited



With a TCAD Unlimited License, a company can complete thousands of TCAD simulations in 24 hours and perform automated Statistical Process Control (SPC) and yield analysis. Currently, companies with a small number of TCAD licenses obtain only a small number of data points over many months, resulting in an incomplete understanding of physics trends and a loss of valuable time to market.

Price is negotiable for one or more years according to company size and includes updates, support and training.



Key Benefits:

- Silvaco offers a TCAD Company Worldwide Unlimited License for one flat annual fee
- Silvaco provides an unlimited number of licenses, which can be configured on multiple license servers, at any of your worldwide locations

TCAD Unlimited includes:

- Unlimited copies of all Silvaco 2D and 3D Process and Device multithreaded TCAD simulators
- Unlimited copies of Interactive Tools such as TonyPlot, DevEdit, DeckBuild and MaskViews
- Unlimited copies of Virtual Wafer Fab (VWF) and SPAYN
- Support for computing farms using LSF and Sun Grid Engines

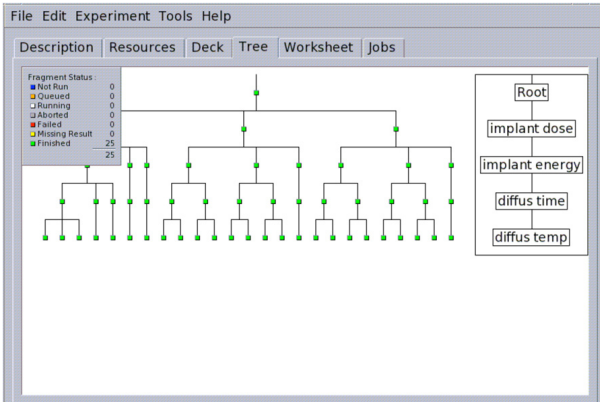

Define and run simulations on any number of machines.

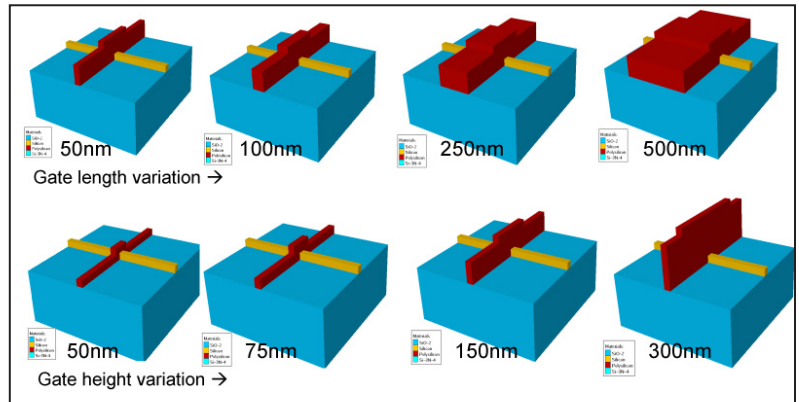

3D FinFET results from many runs showing gate length and height variations. Silicon nitride capping layer is not shown.

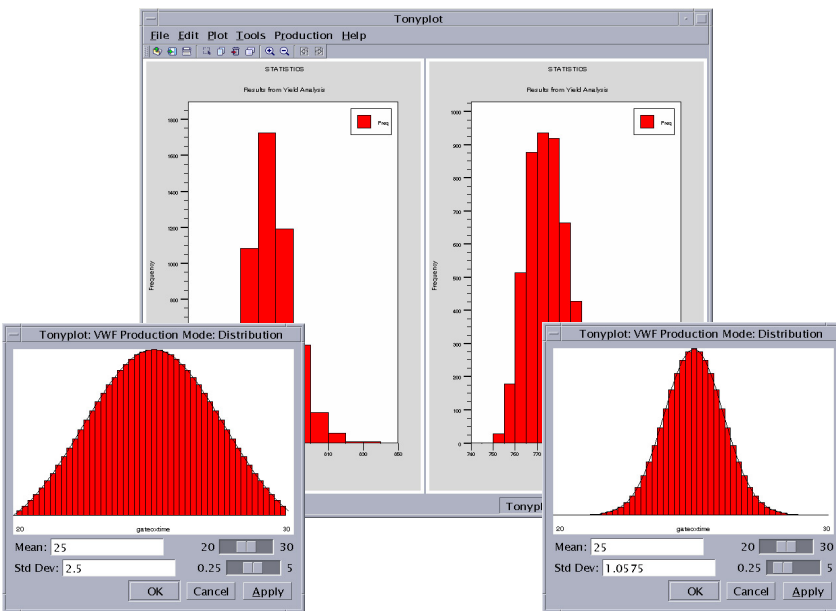

Yield analysis with user selectable statistical distribution. Yield of ring oscillator frequency is shown as a function of different process parameter distribution.

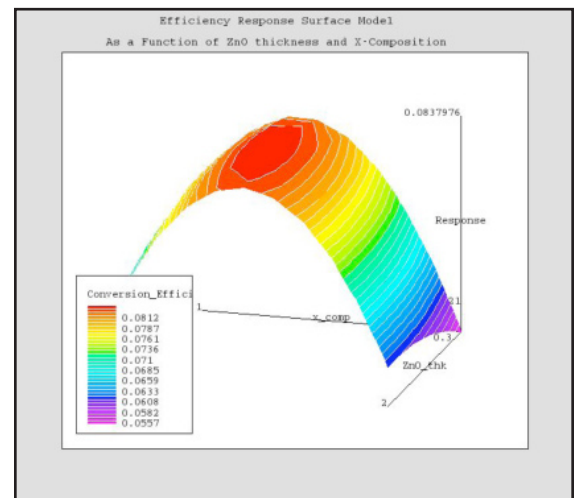

This example shows the Solar Cell Efficiency "Response Surface" using the two variables ZnO thickness and X-Composition. This makes it simple to read off optimum values for cell efficiency.

SILVACO

HEADQUARTERS

4701 Patrick Henry Drive, Bldg. 2

Santa Clara, CA 95054 USA

Phone: 408-654-4309

Fax: 408-496-6080

JAPAN jpsales@silvaco.com

EUROPE eusales@silvaco.com

KOREA krsales@silvaco.com

TAIWAN twsales@silvaco.com

SINGAPORE sgsales@silvaco.com

CALIFORNIA sales@silvaco.com

408-567-1000

MASSACHUSETTS masales@silvaco.com

978-323-7901

TEXAS txsales@silvaco.com

512-418-2929

ARIZONA azsales@silvaco.com

480-947-2900

WWW.SILVACO.COM

Rev 031810_01